

WOLFVISION[®]
Visualizer

INSTRUCTIONS
VZ-5B



English

PRECAUTIONS

Caution:

To reduce the risk of electric shock, do not open the unit.
No userserviceable parts inside. Refer servicing to qualified service personnel only.

Warning:

To reduce the risk of fire or electric shock, do not expose this appliance to rain or moisture.

Manufacturer / Hersteller:

Wolfvision GmbH & Co KG, VlbG. Wirtschaftspark, A-6840 Götztis, Austria
Tel. ++43 / (0)5523 / 52 250-0, Fax ++43 / (0)5523 / 52249

Made in EC (Austria)

Design and specifications subject to change!

Printed in Austria, January 1996

ENGLISH

VZ-5b:

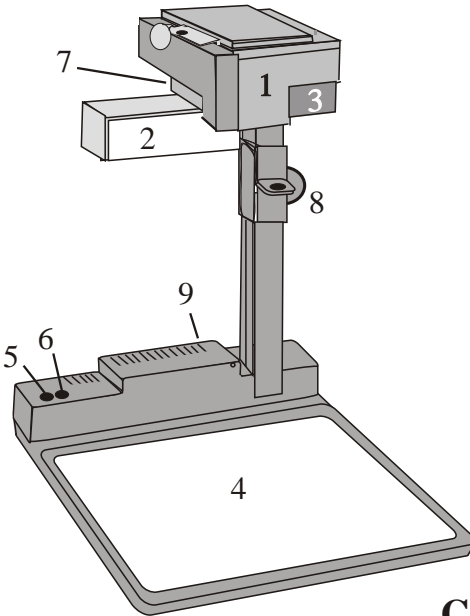

- 1 Video camera head
- 2 Light
- 3 Camera controls (as shown below)
- 4 Working surface
- 5 Power on/off switch
- 6 Light switch
- 7 Close up lens for camera
- 8 Knurled wheel
- 9 Connectors (on back,

Camera controls (3):



- 16 Zoom out button
- 17 Zoom in button
- 18 Auto focus on/off button (the auto focus is continuously operating when the red light is on)

Autofocus:

When switching on the unit the autofocus is automatically switched on too. The correct focus is continuously adjusted at a very high speed.

When the autofocus is switched on the red light on the autofocus on/off switch (18) is on.

Please note that objects with a very low contrast (like a blank sheet of paper) are difficult to focus. If the autofocus does not work just move the object slightly.

Connectors (9):

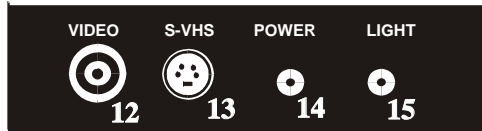

- 12 Composite video output (VBS)
- 13 Y/C (S-VHS) output
- 14 DC input (12 V)
- 15 DC output for light box

Lightbox Handy (optional):

Connect the power cord to the light box connector (15) on the back side of the VZ-5b.

The light switch (6) of the VZ-5b can now be used to switch between the light of the VZ-5b and the light of the lightbox.

For special applications the autofocus can also be switched off using the on/off switch (18).

Manual focusing:

1. Place an object at the level you wish to focus - The autofocus is focusing the object.
2. Switch off the autofocus with the on/off switch (18) - The focus remains unchanged

Setting up

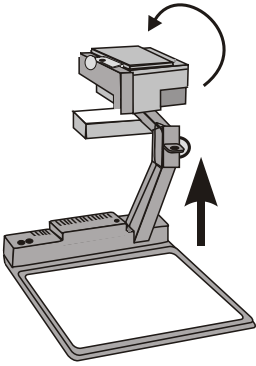

1. Loosen the knurled wheel (8) and pull the arm upwards (Do not pull up on the light unit or camera!)
2. Turn the video camera head (1) and point it at the working surface
3. Connect the power adaptor to the DC-input (14) and plug it in
4. Connect a TV-monitor, a video projector or a video recorder to the video output (12) or the Y/C-output (13)

Please note:

The **picture quality is much better if you use the Y/C (S-VHS) output (13)** rather than the composite video output (12). Especially with typed material in black and white. When using the composite video output please make sure that a dedicated video cable (75W) with RCA plugs is used, and not an audio cable with RCA plugs !!!

5. Switch on the camera with the power switch (5)

White balance:

Please note that the white balance adjustment may not be correct, when switching on the unit. In this case just move any object in the picture. Then it will work correctly.

Shooting area on the working surface:

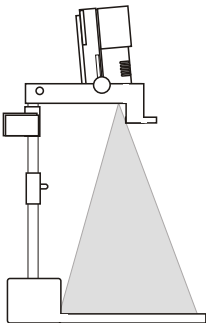

Shooting area outside of the working surface:

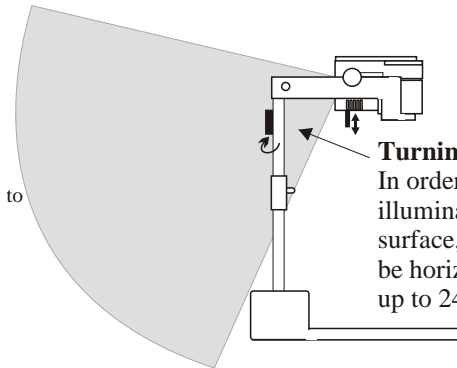

Turning the light backwards

In order to enable recordings with illumination outside of the working surface, the light of the VZ-5b can be horizontally turned an angle of up to 240 degrees.

Eliminating reflections

In order to eliminate reflections (on high gloss photographs etc.) just turn the light backwards slightly.

Please note that reflections can also be caused by the room light.

Close-up adaptor lens

For shooting an object outside the working surface, in a further distance to the unit, the close up lens (7) has to be adjusted.

In this case just pull the lens away from the main optic of the camera until it reaches the locked position. It is impossible to remove the lens completely from the unit, therefore it can not get lost.

Before turning back the camera into the standard working position, push the close up lens back in

Technical data:

Pick-up element / video		VZ-5b
Built-in camera system	1 CCD unit - 1/3" interline transfer	
Effective pixels:	752 x 582 = PAL (VZ-5b E), 768 x 494 = NTSC (VZ-5b U/JE/N)	
Horizontal resolution:	> 450 TV lines	
White balance / Iris / Gain control:	automatic	
Autofocus:	continuously working with high speed, on/off switch	
Optics:	12 x telezoom, 5.4 - 64.8mm, f = 1.8-2.7, with wide macro	
Depth of focus:	14mm (0.6") on smallest picture, size: 31 x 23mm (1.2" x 0.9") 18mm (0.7") on small picture, size: 42 x 33mm (1.7" x 1.3") 200mm (8") on largest picture, size: 360x270mm (14.4"x10.8")	
Operation		
Camera control panel:	functions: zoom in, zoom out, autofocus on/off	
Power and Light controls:	power on/off, light on / off or light on lightbox (external)	
Power-on preset:	autofocus on,	
Lighting element		
Light source:	high frequency neon light	
Light system:	light either on working surface or in front of the unit, back side covered to avoid blinding of audience, low stray light	
Scanning area		
Objects on working surface:	width: 23-270mm (0.9"-10.8"), length: 31-360mm (1.2"-14.4"), height: up to 110mm (4.4") in tele position (smallest picture) up to 400mm (16") in wide position (largest picture)	
Objects in a room:	length, width and height to infinity	
Connections		
Y/C (S-VHS) output:	4-pin connector, Y-signal: 1 Vpp 75W, C-signal: 0.3 Vpp 75W,	
Composite video output:	RCA-connector, VBS 1.0 Vpp 75W	
DC power plug dimensions:	DC in (2,1mm/5,5mm), Lightbox (2,5mm/5,5mm)	
General specifications		
Power consumption:	13 W	
Power source:	12 V DC	
Made in:	European Community (Austria)	
Weight:	VZ-5b: 4.6kg (10lbs), Power pack: 0.7kg (1.5lbs)	
Standard accessories:		
Mains power pack:	100 V, 110 V or 230 V AC / 12 V DC, 1.5 A	
Carrying case (imitation leather):	450x350x132mm (17.7"x13.8"x5.2"), black, with side pocket	
S-VHS (Y/C) cable:	4pin to 4pin	

Specifications and availability subject to change.

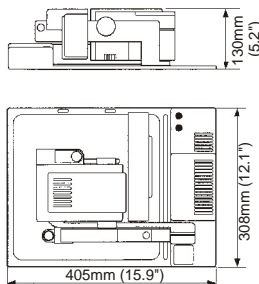
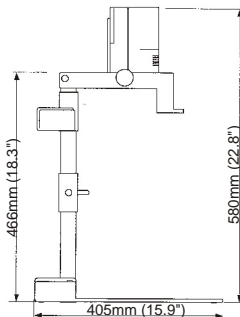

Changing the lamp of the VZ-5b:

1. Remove the power cord of the VZ-5b
2. Remove the philips screw on the bottom of the lamp housing glass
3. Loosen the philips screw on the lamp holder
4. Change the lamp
CAUTION: Hot when used!

Lamp type: Osram Dulux S/E
9W/21 or equivalent