

open:

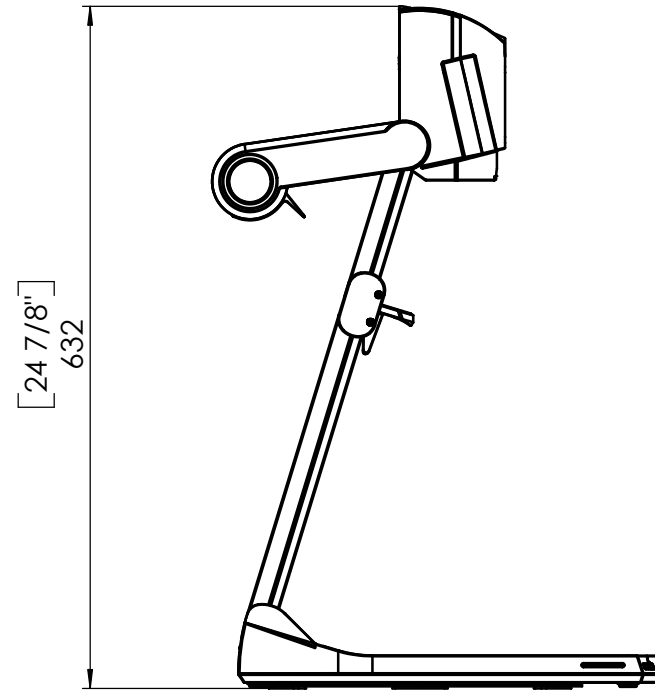

closed:

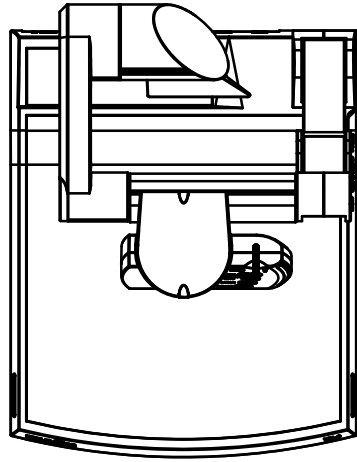
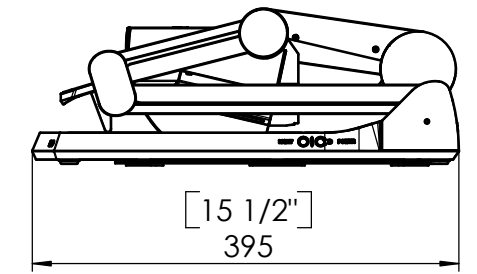
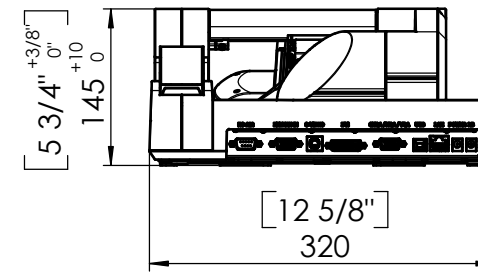

Detail: connectors
M: 1:2

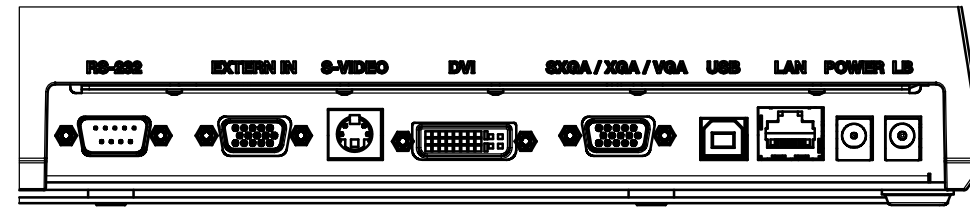

turntable:

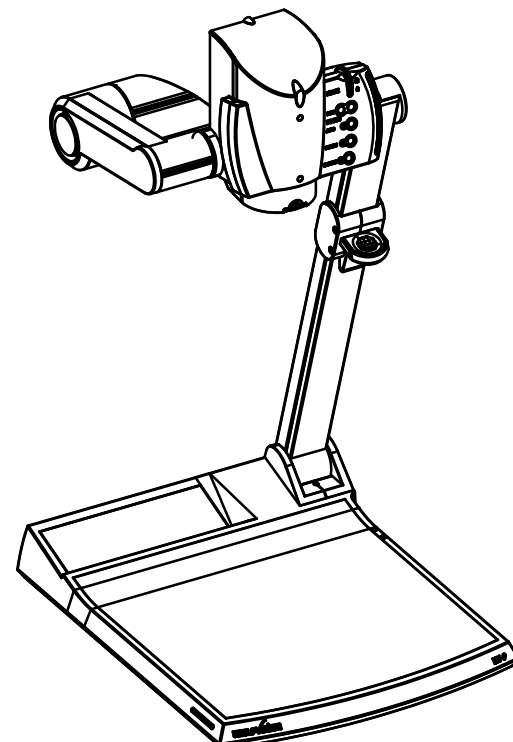
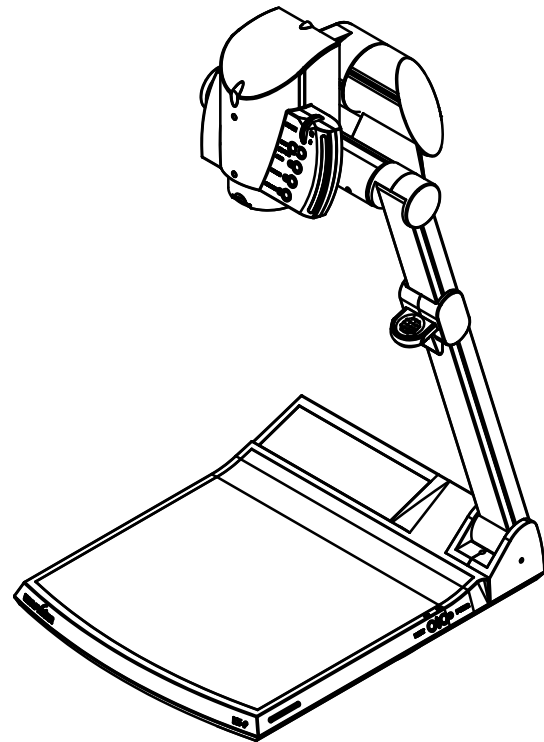
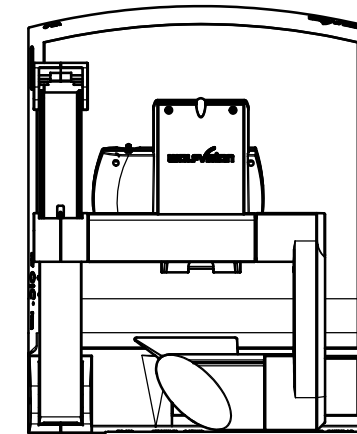
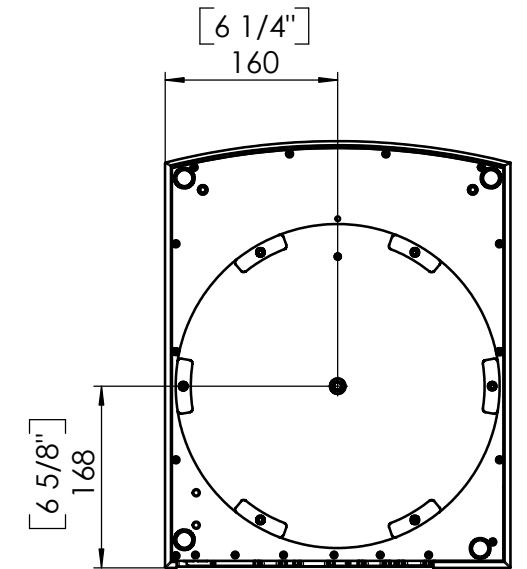

Property of WolfVision GmbH (Ltd.)
Reproduction, copy, or any kind of
duplication of all or partial contents, is strictly
prohibited without prior consent of the proprietor.

<p>Wolfvision GmbH Vilbg. Wirtschaftspark A-6840 Götzis/ Austria Tel.: ++43/(0)5223/52250-0 Fax.: ++43/(0)5223/52249 Mail: wolfvision@wolfvision.com www.wolfvision.com</p>				Zeichnungsnummer:		DIN-Norm		Datum:	Name:
				14-5420EU-00		Maßstab:		Erstellt:	15.03.2005
Dimensions mm / [Zoll]				Freimaß:		1:7	Geprüft:	15.03.2005	WP
							Serienfreig.:		15.03.2005
VZ-9				Nennmaß		Ober- fläche Rz<	Ersetzt:	--	
							Material:		
Version Änd. Dat. NN				Seiten:		1/1	Alle Maße ohne Oberflächenbeschichtung!		
							Status:		