

ITEM NO	QTY	PART NO	DESCRIPTION
1	1	62-141	CEILING PLATE - US
2	2	62-110	CLAMP PLATE ASSEMBLY
3	1	62-143	CAMERA MOUNT WELDMENT
4	1	62-146	TRIM RING WELDMENT
5	2	5900-00056	M3 X 0.5 X 35, PH, P, STL, ZI
6	10	5950-12200	1/4, FL WASHER, STL, ZI
7	10	5950-15700	1/4, LK WASHER, STL, ZI
8	4	6000-11400	1/4-20, HX NUT, GR5, ZI
9	2	5900-00055	1/4-20 X 1/4, SHCS, HX, STL, BO
10	2	5900-20550	1/4, PRS-LOC THUMB SCREW KNOB, BLK
11	6	5900-30950	1/4-20 X 1/2, PH, P, STL, ZI
12	4	5900-39600	1/4-20 X 1, PH, P, STL, ZI
13	1	62-158	PLENUM ENCLOSURE

UNLESS OTHERWISE SPECIFIED  
DIMENSIONS ARE IN INCHES.  
TOLERANCES:  
.XX = ± .02  
.XXX = ± .010  
.XXXX = ± .0050  
ANGLE = ± 0.5

**WOLFVISION**  
*Visualizer*  
TILE BRIDGE - US  
WOLFVISION EYE SERIES

DRAWN	CRH	DATE	4/3/2006	SIZE	DRAWING NO.	REV
CHECKED		DATE		<b>B</b>	62-150	<b>C</b>
MATERIAL	-			SCALE	FILE NAME	
FINISH	-			NONE	62-150.SLDDRW	SHEET 3 OF 4

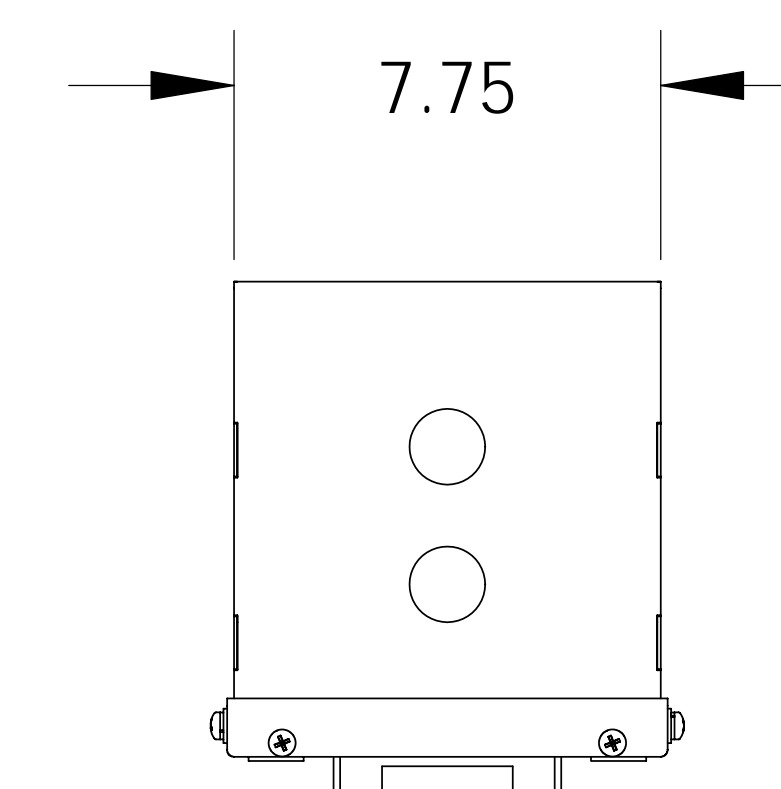
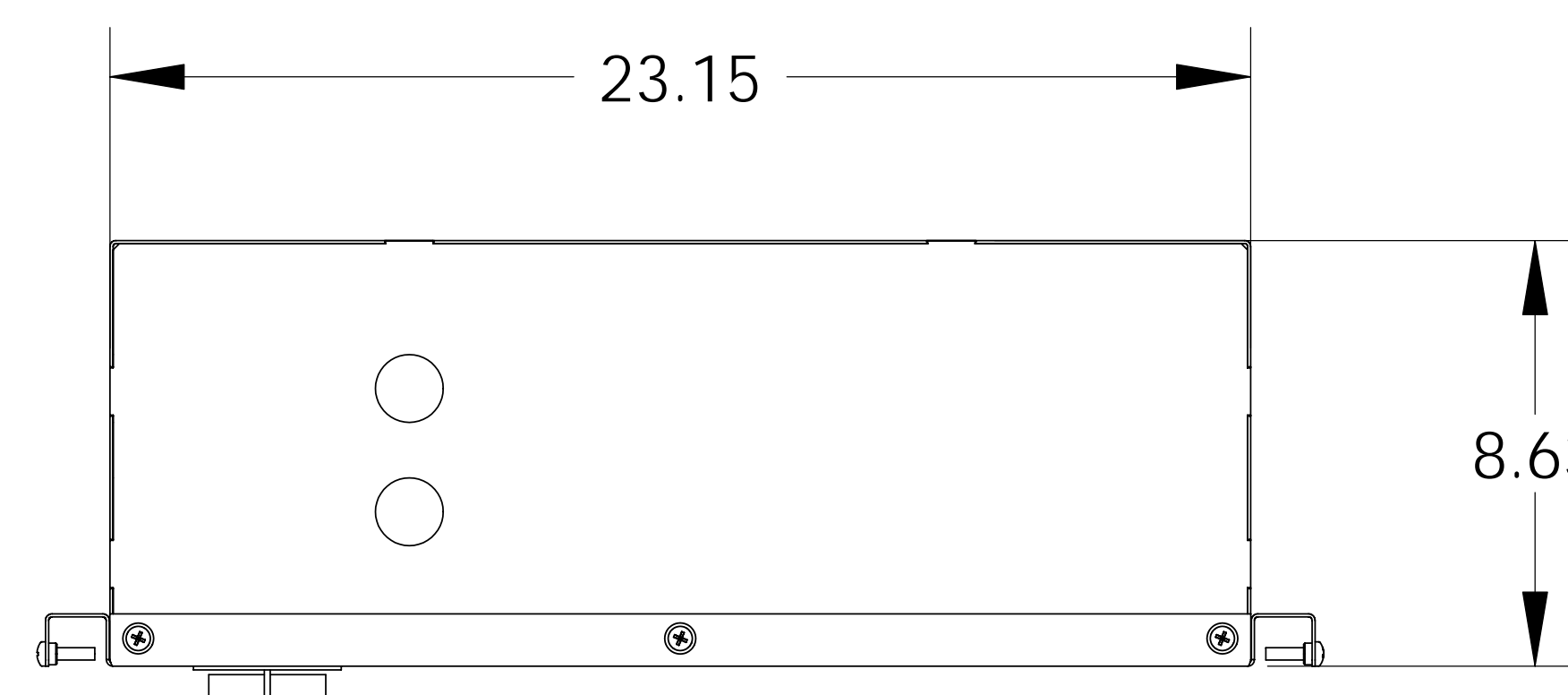
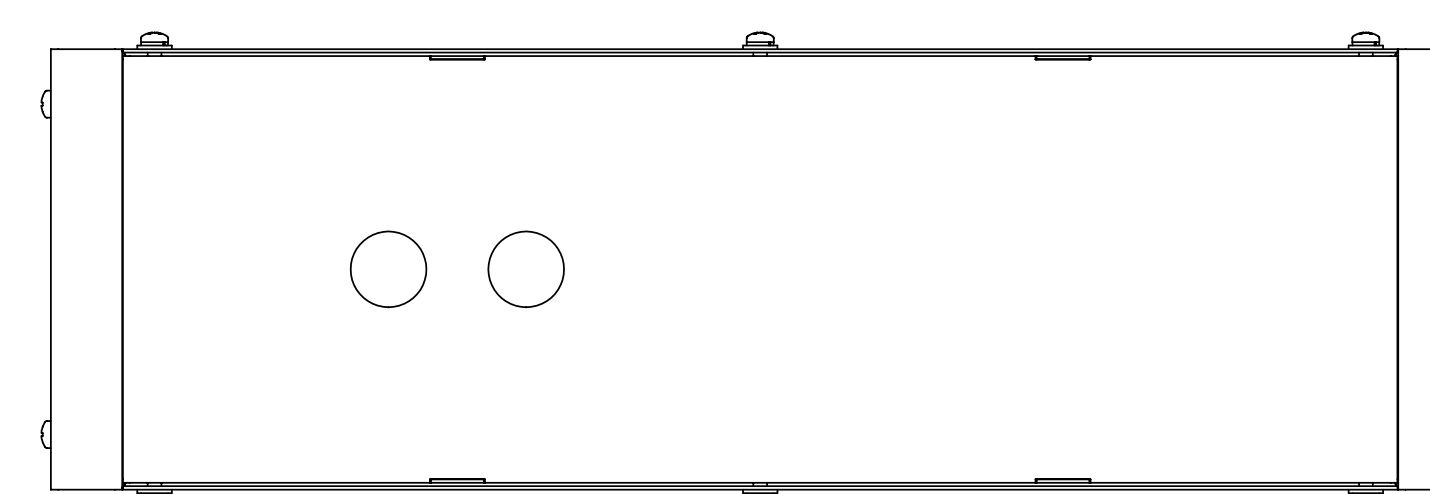
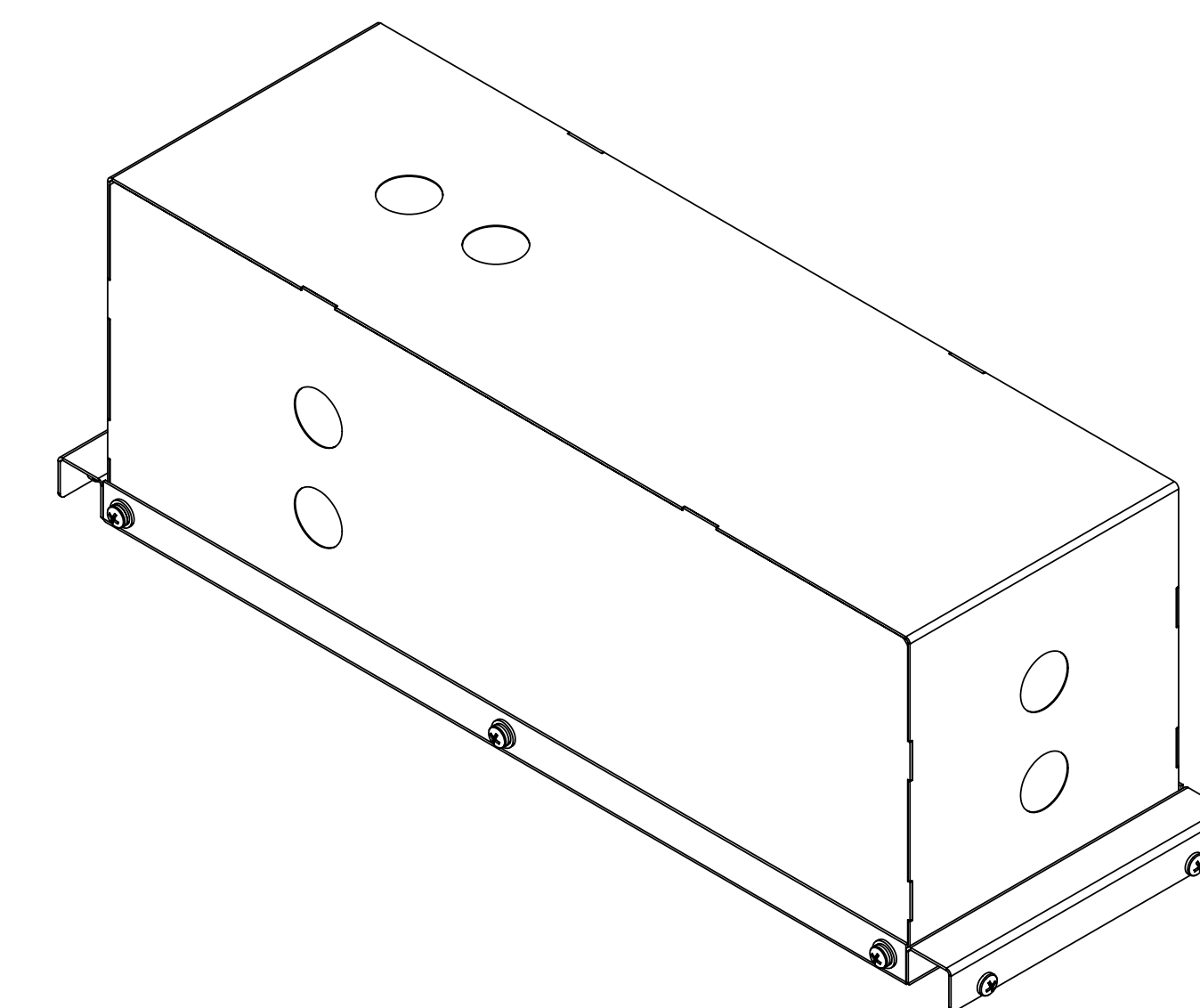
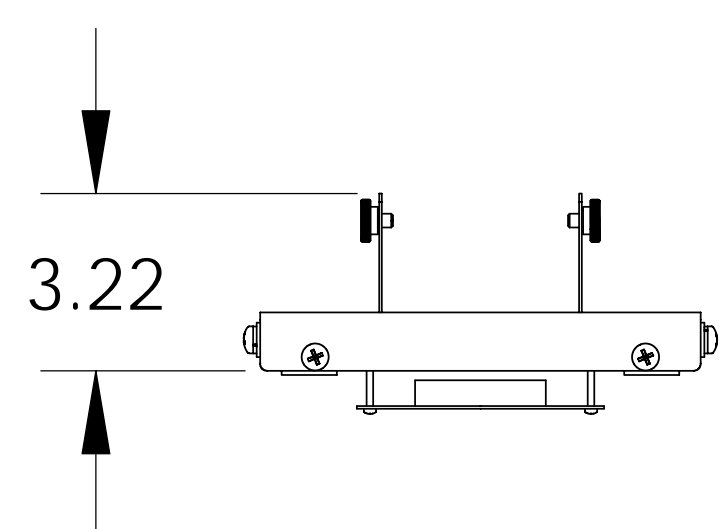
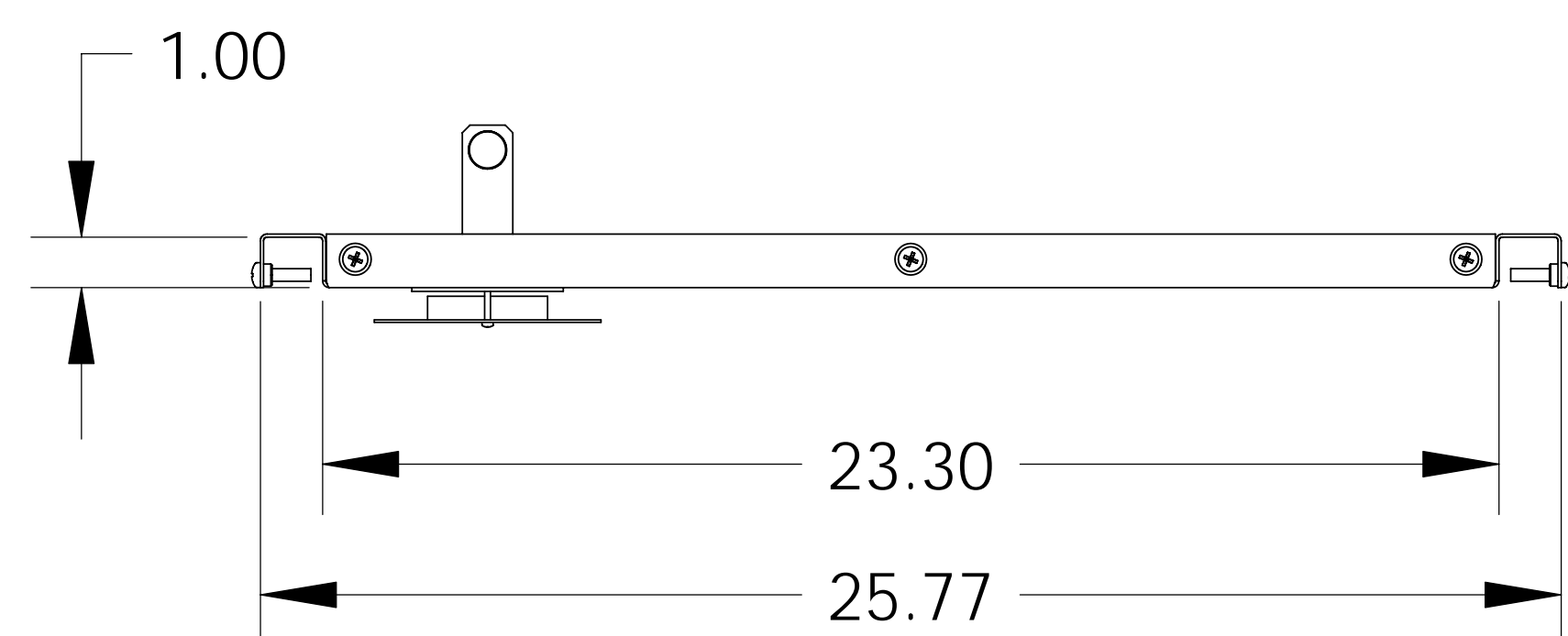
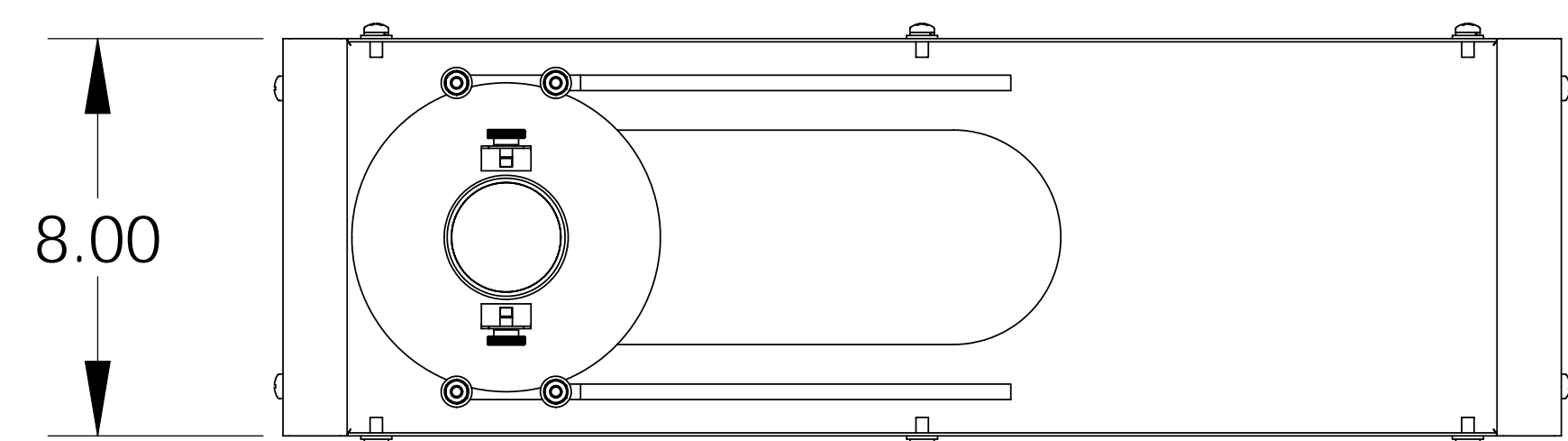
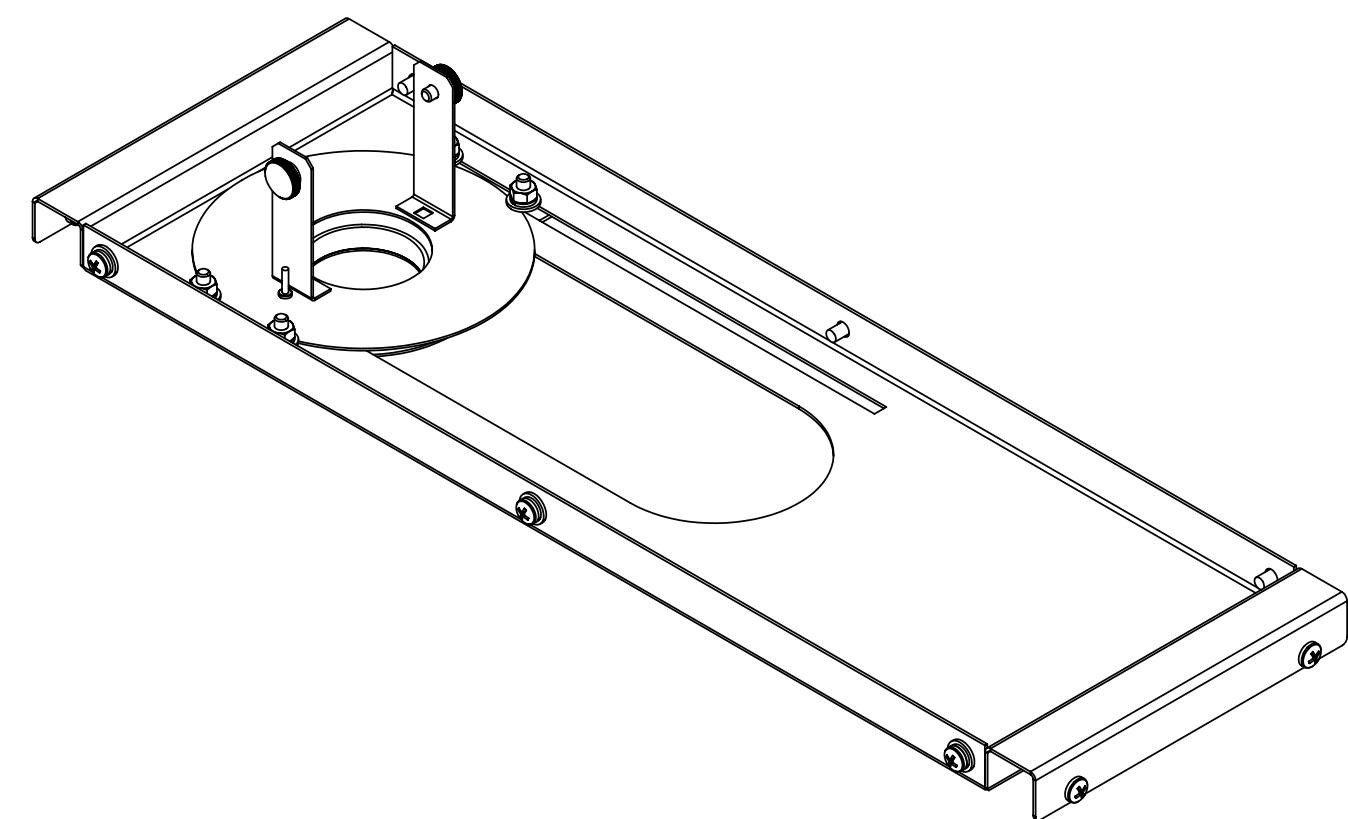

UNLESS OTHERWISE SPECIFIED  
DIMENSIONS ARE IN INCHES.  
TOLERANCES:  
.XX = ± .02  
.XXX = ± .010  
.XXXX = ± .0050  
ANGLE = ± 0.5

**WOLFVISION**  
*Visualizer*  
TILE BRIDGE - US  
WOLFVISION EYE SERIES

DRAWN	CRH	DATE	4/3/2006	SIZE	DRAWING NO.	REV
CHECKED		DATE		<b>B</b>	62-150	<b>C</b>
MATERIAL	-			SCALE	FILE NAME	
FINISH	-			NONE	62-150.SLDDRW	SHEET 4 OF 4